

**NOVOHALL
Rotary Sensor
non-contacting**

Series RSX-7900



Special features

- very robust design to extreme environmental conditions
- high shaft load 300 N
- non-contacting, magnetic
- measuring angles up to 360° in single and multi-channel versions
- enhanced corrosion protection by anodized aluminum housing and stainless steel shaft, salt spray resistant
- very good linearity
- resolution 14 bit
- unlimited mechanically rotatable
- absolutely impermeable to splash-water IP6K9K
- high temperature resistance
- long life >100 million movements, even at vibration-loaded mounting positions
- For highest EMC requirements such as ISO pulses and interference fields according to ISO 11452 and ECE directive
- Suitable for use in safety-related applications according to ISO 13849

Applications

- Position measurement in steering systems
- pivotable vehicle bracings
- Transport systems with several axes
- Construction and agricultural machinery

The angle sensor RSX-7900 is designed for use in mobile applications under extreme environmental conditions. The sensor is suitable for a continuously ambitious operating. The robust full metal housing with a double ball bearing stainless steel shaft and a superior seal concept protects the sensor against various environmental influences. The high accuracy and reliability of the magnetic angle measurement are further features, particularly in safety-related applications.

The massive but compact design allows direct mounting of the sensor without additional protective measures. A variety of shaft versions allows guidance via lever arm or other driving elements.

Zentrierung am Gehäuse an Wellenseite
Centering shaft side
RSX-791

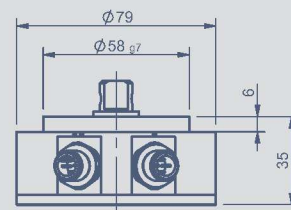

Zentrierung am Gehäuse an Wellen- und Deckelseite
Centering shaft and cover side
RSX-794

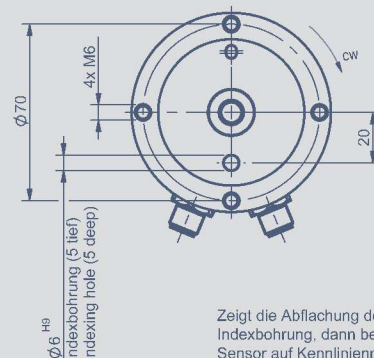
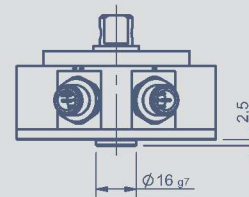

Zeigt die Abflachung der Welle in Richtung Indexbohrung, dann befindet sich der Sensor auf Kennlinienmitte. When the flattening of the shaft points towards the indexing hole, the sensor is near the electrical center position.

Description

Housing	anodized aluminum, AlMgSi1, salt spray resistant
Shaft	stainless steel 1.4305 / X10CrNiS18-9
Bearing	double angular ball bearing
Electrical connections	cable with cable screw connection or M12x1 connector

Contents

Mechanical Data	3
Characteristics	4
Technical Data Analog Interface	5
Ordering Specifications	6
Technical Data CANopen Interface	7
Ordering Specifications	8
Accessories	
Sensor mounting	9
M12 Connector System	10

Mechanical Data

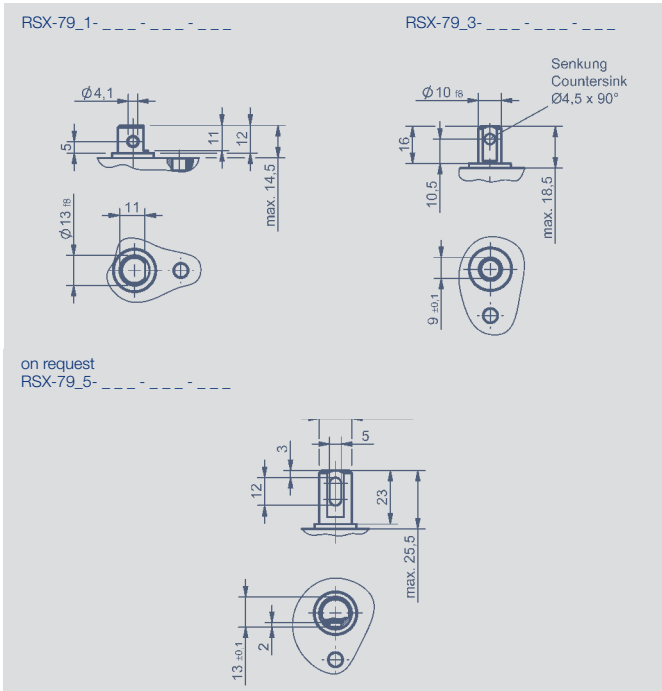

Mechanical Data

Dimensions	see dimension drawing	
Mounting	with 4 screws M6, screw-in depth 15 mm min.	
Starting torque of mounting screws	8 ± 1	Nm
Mechanical travel	360 continuous	°
Permitted shaft loading (axial and radial) static or dynamic force	300	N
Torque *	max. 4	Ncm
Maximum operational speed	50	min-1
Weight	approx. 500	g

Environmental Data

Operating temperature	-40 ... +85 (analog),	°C
	-40 ... +105 (CAN)	°C
Vibration (IEC 60068-2-6)	5...2000	Hz
	A _{max} = 0.75	mm
	a _{max} = 20	g
Shock (IEC 60068-2-27)	50 (6 ms)	g
Protection class (DIN EN 60529)	IP67 M12 connector outlet IP6K9K cable outlet	
Life	>100x10 ⁶	movements

*) Depending on the environmental temperature and standstill time, the necessary force for the initial operating of the shaft may increase

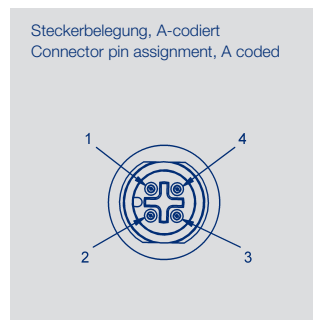
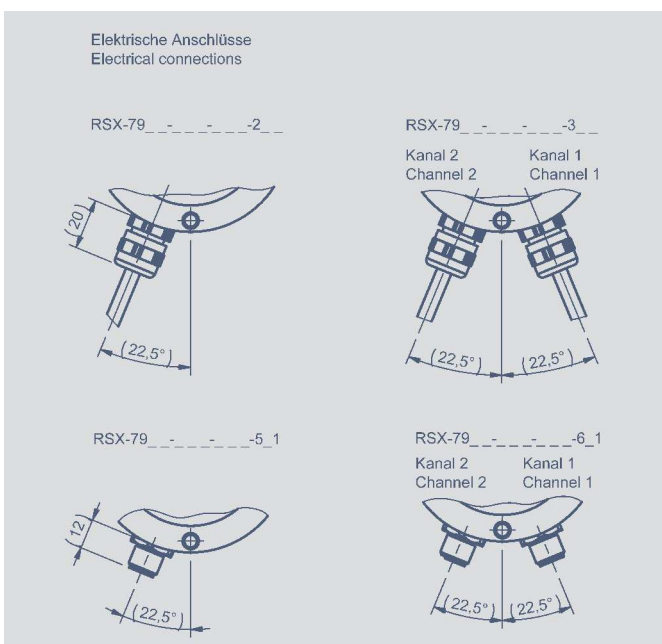

CAD data see www.novotechnik.de/enddownloads/cad-data/

Characteristics

One channel, rising cw

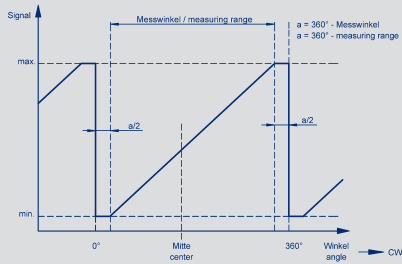

One channel, rising ccw

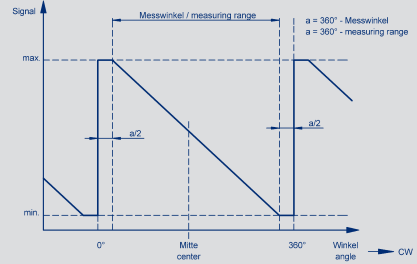

Crossed characteristics, channel 1 cw

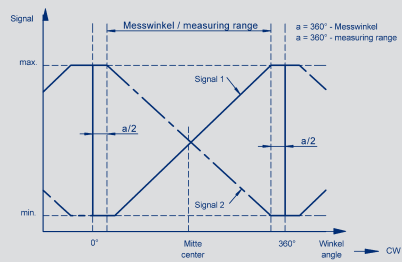

On request:
two channel, signal 2 = 0,5 x signal 1

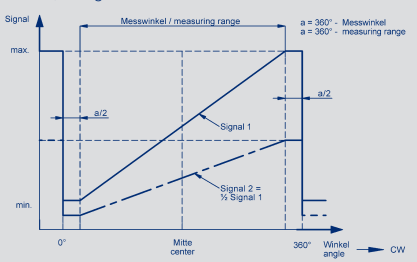

On request:
Trapeze characteristic

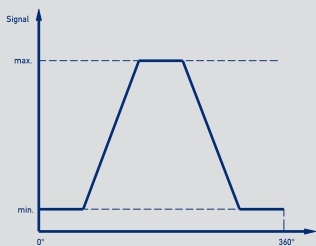

On request:
different gradients

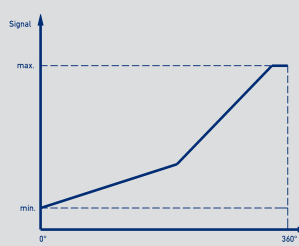

On request:
2 staggered characteristics

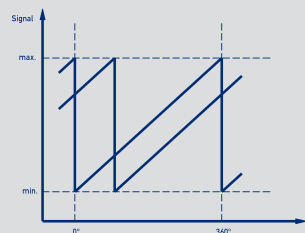

On request:
Parabolic characteristic

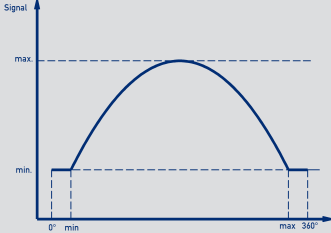

Technical Data
Analog Interface
- Current



Electrical Data	RSX-79 _ _ _ _ _ -32 _ _ _ _ _ analog Current	
Supply voltage Ub	12/24 (9 ... 34)	VDC
Current consumption (w/o load)	typical 20 per channel, supply voltage Ub = 24 V	mA
Reverse voltage	yes	
Short circuit protection	yes, all outputs vs. GND and supply voltage Ub	
Measuring range	60, 120, 180, 240, 300, 360	°
Number of channels	1 / 2	
Update rate	5	kHz
Resolution	12	bit
Repeatability	0.2	°
Hysteresis at measuring range < 360°	0.1	°
Hysteresis at measuring range 360°	0.25 (lower hysteresis on request)	°
Absolute linearity at measuring range < 90°	2.0	±%FS
Absolute linearity at measuring range ≥ 90°	1.0	±%FS
Interlinearity at measuring range < 90°	4.0	±%FS
Interlinearity at measuring range ≥ 90°	2.0	±%FS
Output signal	4 ... 20 (burden max. 250 Ω)	mA
Temperature error at measuring range < 90°	200	ppm/K
Temperature error at measuring range ≥ 90°	160	ppm/K
Insulation resistance (500 VDC)	≥ 10	MΩ
Cross-section cable	0.5 (AWG 20)	mm ²
EMC Conformity	ISO 10605 Packaging and Handling + Component Test (ESD) 8 kV, 15 kV ISO 11452-2 Radiated EM HF-Fields, Absorber Hall: 100 V/m ISO 11452-5 Radiated EM HF-Fields, Stripline 200 V/m CISPR 25 Radiated and conducted emission class 5 ISO 7637-2 Pulse 1, 2a, 2b, 3a, 4, 5 SG 4 ISO 7637-3 Transient emission SG 4 Interference emission and immunity according to ECE-R10 (E1)	
Functional safety	Suitable for safety-relevant applications according to ISO 13849 after customer validation. Further safety data (DCavg...) and support for functional safety are available on request.	
MTTF (DIN EN ISO 13849-1 parts count method, w/o load, wc)	46 (per channel)	years
MTTFd (DIN EN ISO 13849-1 parts count method, w/o load, wc)	92 (per channel)	years
MTTF certificate s. https://www.novotechnik.de/en/downloads/certificates/mttf-certificates/		

Pin assignment

Single channel version

	Cable (Code -252)	M12 connector (Code -551)
Supply Ub	GN	Pin 1
GND	BN	Pin 3
Signal	WH	Pin 2
Not assigned	YE	Pin 4
Partly redundant version		
	Cable (Code -252)	M12 connector (Code -551)
Supply Ub	GN	Pin 1
GND	BN	Pin 3
Signal 1	WH	Pin 2
Signal 2	YE	Pin 4

Fully redundant version

	2 x Cable (Code -352)	2 x M12 connector (Code -651)
Supply Ub 1	Channel 1 / GN	Channel 1 / Pin 1
GND 1	Channel 1 / BN	Channel 1 / Pin 3
Signal 1	Channel 1 / WH	Channel 1 / Pin 2
Supply Ub 2	Channel 2 / GN	Channel 2 / Pin 1
GND 2	Channel 2 / BN	Channel 2 / Pin 3
Signal 2	Channel 2 / YE	Channel 2 / Pin 4
Not assigned	Channel 1 / YE4 Channel 2 / WH	Channel 1 / Pin 4 Channel 2 / Pin 2

Ordering specifications
Analog Interface
- Current

Ordering specifications

Preferred types printed in bold

Supply U_b / interface
3: $U_b = 12/24\text{ V}$ (9 ... 34 V)

Output signal
2: 4 mA ... 20 mA
Other output signals on request

Output characteristic
1: rising CW
2: rising CCW
3: Partly redundant version: crossed output channel 1 rising / channel 2 falling CW
4: Fully redundant version: crossed output channel 1 rising / channel 2 falling CW
Other characteristics on request

Electrical connection
single channel / partly redundant version: 1 output
252: 1 x cable 4-pole, 2 m, unshielded
551: 1 x connector M12, 4-pin, unshielded
Fully redundant version: 2 outputs
352: 2 x cable 4-pole, 2 m, unshielded
651: 2 x connector M12, 4-pin, unshielded
Cable versions and assembled connectors on request

R S X - 7 9 1 1 - 8 3 6 - 3 2 4 - 3 5 2

Series

Measuring range

06: 60°
12: 120°
18: 180°
24: 240°
30: 300°
36: 360°

Other angles on request

Number of channels

6: single channel version (1 x U_b , 1 x output)
7: partly redundant version (1 x U_b , 2 x output)
8: fully redundant version (2 x U_b , 2 x output)

Shaft

1: Ø 13x12 mm with cross hole Ø 4,1 mm
3: Ø 10x16 mm with countersink Ø 4.5x90°

Other shaft versions on request

Housing

1: Centering shaft side
4: Centering shaft and cover side

Model / size
79: 79 x 35 mm

Technical Data

CANopen®



Type Designations	RSX-79 _ _ -214-6 _ _ - _ _ _ CANopen	
Electrical Data		
Measured variables	Position and speed	
Measuring range	360	°
Number of channels	1 / 2	
Output signal / protocol	CANopen protocol to CiA DS-301 V4.2.0, Device profile DS-406 V3.2 Encoder Class C2, LSS services to CiA DS-305 V1.1.2	
Programmable parameter	Position, speed, cams, working areas, rotating direction, scale, offset, node-ID, baud rate	
Node-ID	1 ... 127 (default 127)	
Baud rate	50 ... 1000	kBaud
Resolution across 360° (position)	14	bit
Resolution speed	360/2 ¹⁴ ≈ 0.022	°/ms
Update rate	1	kHz
Independent linearity	one-channel: ≤ 0.5 / two-channel: ≤ 0.85	±% FS
Repeatability	≤ 0.36	°
Hysteresis	≤ 0.36	°
Temperature error	0.2	±% FS
Supply voltage Ub	12/24 (8 ... 34)	VDC
Current consumption (w/o load)	< 100	mA
Reverse voltage	yes, supply lines	
Short circuit protection	yes, output vs.GND and supply voltage Ub (up to 40 VDC)	
Overvoltage protection	< 45 (permanent)	VDC
Insulation resistance (500 VDC)	≥ 10	MΩ
Cross-section cable	0.5 (AWG 20)	mm ²
Bus termination internal	120, optionally	Ω
Environmental Data		
MTTF (DIN EN ISO 13849-1 parts count method, w/o load, wc)	one-channel: 61 / two-channel: 58 (per channel)	years
Functional safety	If you need assistance in using our products in safety-related systems, please contact us	
EMC compatibility	ISO 10605 Packaging and Handling + Component Test 8 kV ISO 11452-2 Radiated EM RF fields, Absorberhall 100 V/m ISO 11452-5 Radiated EM RF fields, Stripline 200 V/m CISPR 25 Radiated emission class 3 ISO 7637-2 Pulse 1, 2a, 2b, 3a, 3b, 4, 5 SG 3 ISO 7637-3 Transient transmission SG 4 EN 13309 Construction machinery Interference emission and immunity according to ECE-R10 (E1)	

Connection assignment

Signal	Cable Code 2 _ _ / 3 _ _	Connector M12 Code 5 _ _ / 6 _ _
CAN_SHLD	Shield	pin 1
Supply voltage Ub	WH	pin 2
GND	BN	pin 3
CAN_H	YE	pin 4
CAN_L	GN	pin 5

Cable shielding connect to GND.

Ordering Specifications



Ordering specifications

Preferred types printed in bold

Interface

6: CANopen Interface

Interface parameters CANopen 6 _ _

- 1: 1 x position, 1 x speed**
- 2: 2 x position, 2 x speed**
- 5: 1 x position, 1 x speed with bus termination 120 Ω
- 6: 2 x position, 2 x speed with bus termination 120 Ω

Baud rate

- 1: Baud rate 1000 kBaud**
- 2: Baud rate 800 kBaud**
- 3: Baud rate 500 kBaud**
- 4: Baud rate 250 kBaud**
- 5: Baud rate 125 kBaud**
- 7: Baud rate 50 kBaud**

Electrical connection

- 1 Output**
- 201: 1 x cable 4-pole 1.0 m, shielded**
- 511: 1 x connector M12, 5-pole, shielded**
- 2 Outputs (CAN IN/OUT)**
- 301: 2 x cable 4-pole 1.0 m, shielded**
- 611: 2 x connector M12, 5-pole, shielded**

R S X - 7 9 1 1 - 2 1 4 - 6 1 5 - 5 1 1

Series

Shaft

- 1: Ø 13x12 mm with cross hole Ø 4,1 mm**
- 3: Ø 10x16 mm with countersink Ø 4.5x90°**
- Other shaft versions on request

Housing

- 1: Centering shaft side**
- 4: Centering shaft- and cover side

Model / size

79: 79 x 35 mm

Accessories

Sensor mounting

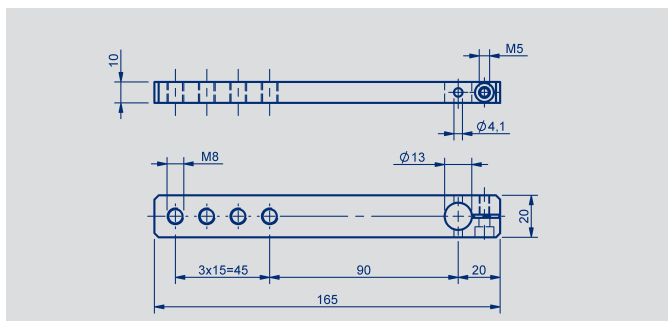

Z-IPX-M01

Lever arm 165 x 20 mm for pivot head drive

- aluminum, anodized
- for shaft RSX-79_1-...
- P/N 400105430

Assembly material (screw, locking pin) included in delivery

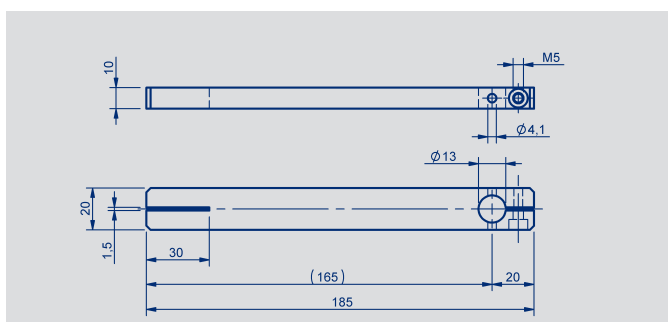

Z-IPX-M11

Lever arm 185 x 20 mm for lever arm drive, clamp connection on dimension 20 mm

- aluminum, anodized
- for shaft RSX-79_1-...
- P/N 400105431

Assembly material (screw, locking pin) included in delivery

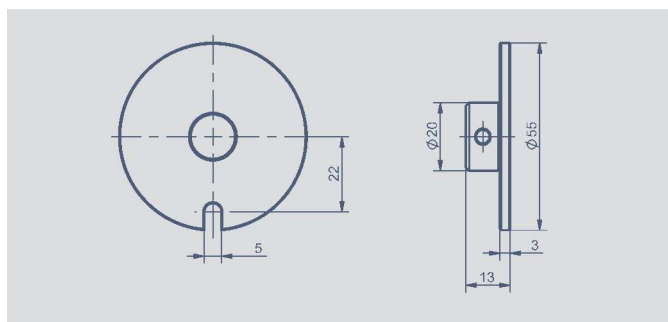

Z-IPX-M21

Driving plate D = 55 mm for lateral shaft drive with locking pin

- aluminum, anodized
- for shaft IPX-79_1-...
- P/N 400105433

Assembly material (locking pin) included in delivery

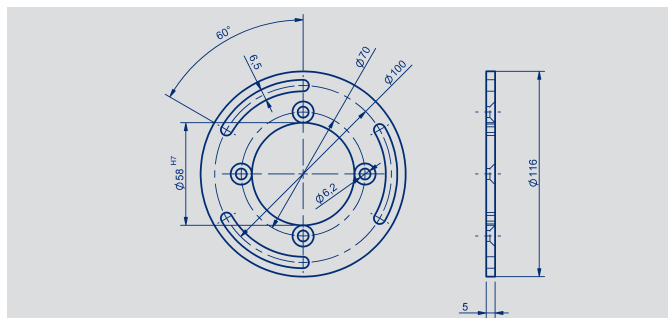

Z-IPX-M31

Mounting plate for adjustable mounting on screw-hole circle 100 mm

- aluminum, anodized
- P/N 400105432

Assembly material (4 x countersink screw) included in delivery

Accessories
Connector System M12

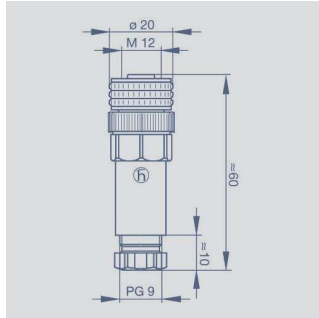

Pin assignment

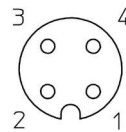

M12x1 Mating female connector, 4-pin, straight, A-coded, with coupling nut, screw termination, IP67, not shieldable

Connector housing	Plastic PBT -25 °C...+90 °C
For wire gauge	6...8 mm, max. 0,75 mm ²
Type	EEM 33-88, P/N 400005633

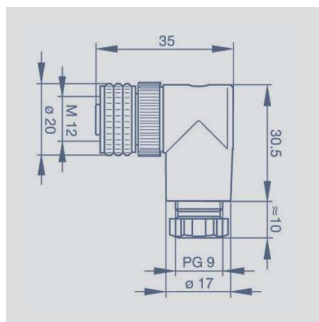

Pin assignment

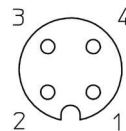

M12x1 Mating female connector, 4-pin, angled, A-coded, with coupling nut, screw termination, IP67, not shielded

Connector housing	Plastic PBT -25 °C...+90 °C
Für wire gauge	6...8 mm, max. 0.75 mm ²
Type	EEM 33-89, P/N 400005634

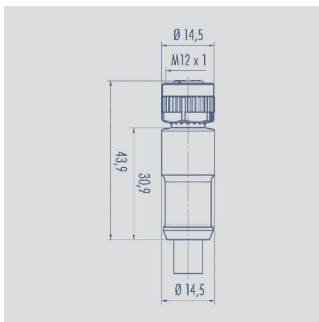

Pin assignment

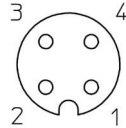

- 1 = brown
- 2 = white
- 3 = blue
- 4 = black



M12x1 Mating female connector, 4-pin, straight, A-coded, with molded cable, not shielded, IP67, open ended

Connector housing	Plastic PA
Cable sheath	PUR; Ø = max. 6 mm, -40 °C...+85 °C (fixed)
Wires	PP, 0,34 mm ²
Length	Type P/N
2 m	EEM 33-35 400056135
5 m	EEM 33-36 400056136
10 m	EEM 33-37 400056137

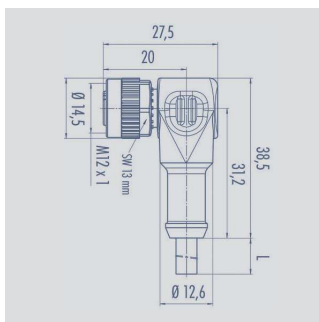

Anschlussbelegung

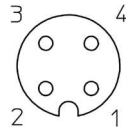

- 1 = brown
- 2 = white
- 3 = blue
- 4 = black



M12x1 Mating female connector, 4-pin, angled, A-coded, with molded cable, not shielded, IP67, open ended

Connector housing	Plastic PA
Cable sheath	PUR; Ø = max. 6 mm, -40 °C...+85 °C (fixed)
Wires	PP, 0,34 mm ²
Länge	Type P/N
2 m	EEM 33-38 400056138
5 m	EEM 33-39 400056139
10 m	EEM 33-40 400056140

Accessories
Connector System M12

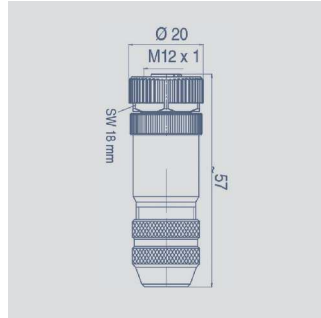

Pin assignment

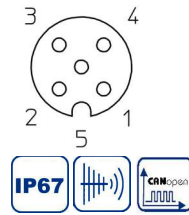

M12x1 Mating female connector, 5-pin, straight, A-coded, with coupling nut, screw termination, IP67, shielded, CAN-bus

Connector housing Metall
-40 °C...+85 °C

For wire gauge 6...8 mm, max. 0.75 mm²

Type EEM 33-73, P/N 400005645

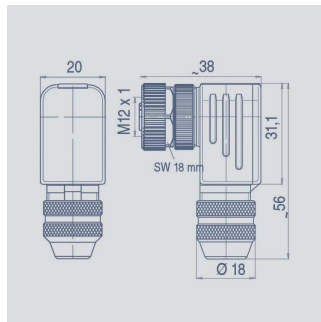

Pin assignment

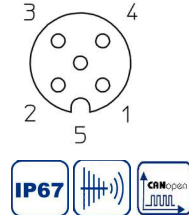

M12x1 Mating female connector, 5-pin, angled, A-coded, with coupling nut, screw termination, IP67, shielded, CAN-Bus

Connector housing Metall
-40 °C...+85 °C

For wire gauge 6...8 mm, max. 0.75 mm²

Type EEM 33-75, P/N 400005646

It is possible to turn and fix the contact carrier in 90° positions.

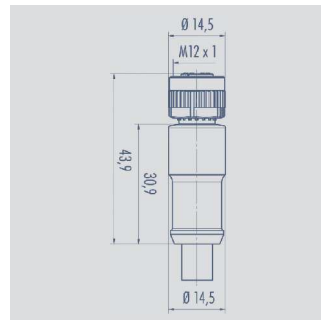

Pin assignment

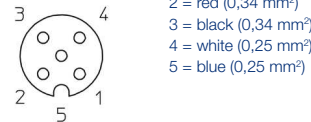

- 1 = shield
- 2 = red (0,34 mm²)
- 3 = black (0,34 mm²)
- 4 = white (0,25 mm²)
- 5 = blue (0,25 mm²)

M12x1 Mating female connector, 5-pin, straight, A-coded, with molded cable, IP67, shielded, open ended, CAN-Bus

Connector housing PUR

Cable sheath PUR Ø = max. 7.2 mm,
-25 °C...+85 °C (moved)

Wires PP 2x 0.25 mm²
+ 2 x 0.34 mm²

Length	Type	P/N
2 m	EEM 33-41	400056141
5 m	EEM 33-42	400056142
10 m	EEM 33-43	400056143

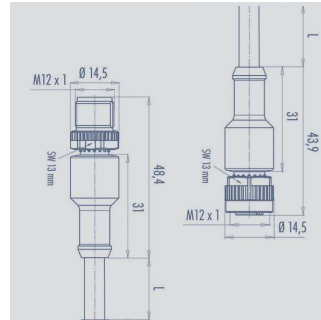

Pin assignment

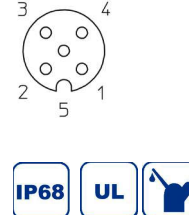

M12x1 Mating connector, 5-pin, straight, A-coded, with molded cable, IP68, CAN-Bus

Connector housing PUR

Cable sheath PUR; Ø 7.2 mm
-25 °C... +85 °C (fixed)

Length	Type	P/N
5 m	EEM 33-44	400056144

IP67 Protection class to DIN EN 60529

IP68 Protection class to DIN EN 60529

CAN-open CAN-bus

UL UL - approved

Very good resistance to oils, coolants und lubricants

Very good Electromagnetic Compatibility (EMC) and shield systems

Note: The protection class is valid only in locked position with its plugs. The application of these products in harsh environments must be checked in particular cases

Novotechnik U.S., Inc.
155 Northboro Road
Southborough, MA 01772
Phone 508 485 2244
Fax 508 485 2430
info@novotechnik.com
www.novotechnik.com

© 09/2017
Printed in Germany.

The specifications contained in our datasheets are intended solely for informational purposes. The documented specification values are based on ideal operational and environmental conditions and can vary significantly depending on the actual customer application. Using our products at or close to one or more of the specified performance ranges can lead to limitations regarding other performance parameters. It is therefore necessary that the end user verifies relevant performance parameters in the intended application. We reserve the right to change product specifications without notice.